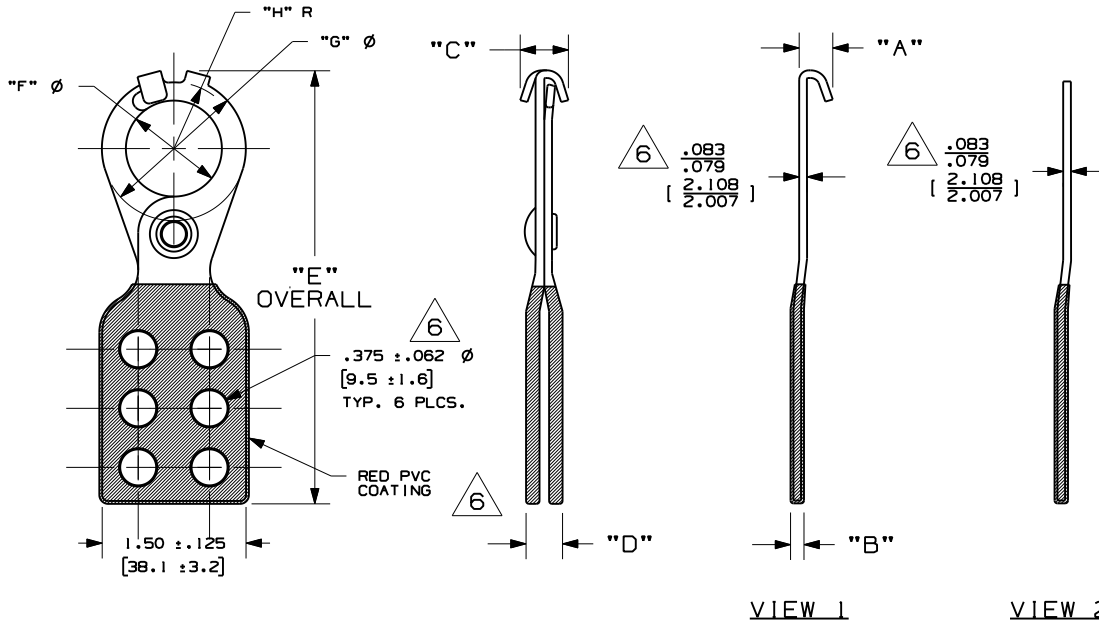

TABLE 2

P/N	"A"	"B"	"C"	"D"	"E" OVERALL	"F"	"G" DIA.	"H" R.
PSL-1	.370 +/- .030 [9.4 +/- 0.8]	.140 +/- .030 [3.6 +/- 0.8]	.550 +/- .063 [14.0 +/- 1.6]	.375 +/- .063 [9.5 +/- 1.6]	4.50 +/- .12 [114.3 +/- 3.1]	1.00 +/- .04 [25.4 +/- 1.0]	1.50 +/- .04 [38.1 +/- 1.0]	0.69 +/- .04 [17.5 +/- 1.0]
PSL-1.5	.330 +/- .030 [8.4 +/- 0.8]		.490 +/- .063 [12.4 +/- 1.6]		5.05 +/- .12 [128.3 +/- 3.1]	1.50 +/- .04 [38.1 +/- 1.0]	2.12 +/- .04 [53.8 +/- 1.0]	1.03 +/- .04 [26.2 +/- 1.0]
PSL-1A	N/A		N/A		4.40 +/- .12 [111.8 +/- 3.1]	1.00 +/- .04 [25.4 +/- 1.0]	1.50 +/- .04 [38.1 +/- 1.0]	0.69 +/- .04 [17.5 +/- 1.0]
PSL-1.5 A	N/A		N/A		4.95 +/- .12 [125.7 +/- 3.1]	1.50 +/- .04 [38.1 +/- 1.0]	2.12 +/- .04 [53.8 +/- 1.0]	1.03 +/- .04 [26.2 +/- 1.0]

- NOTES:
 1. DIMENSIONS SHOWN IN BRACKETS ARE IN MILLIMETERS.
 2. VIEW 1. (OVERLAPPING TABS) AND VIEW 2. (NON-OVERLAPPING TABS) SHOW ONLY ONE HALF OF LOCKOUT.



6

TABLE 1			
PART NUMBER	DESCRIPTION	MAX. NO. LOCKS.	STANDARD PKG.
PSL-1	HASP WITH 1.0" (25 mm) DIA. JAW AND OVERLAPPING TABS	6	12
PSL-1.5	HASP WITH 1.5" (38 mm) DIA. JAW AND OVERLAPPING TABS	6	12
PSL-1A	HASP WITH 1.0" (25 mm) DIA. JAW	6	12
PSL-1.5A	HASP WITH 1.5" (38 mm) DIA. JAW	6	12

VIEW 1

VIEW 2

CAD FILENAME/LAYERS

100318MU_DC_C10099/01G

REV	DATE	BY	CHK	DESCRIPTION	ECN	R	CUST	SUP
6	7/21/09	RVU		.375 +/- .062 Ø WAS .375 +/- .125 Ø. C1018 WAS C108. .083/.079 WAS .080/.079. ADD "TABLE 1 & TABLE 2" ONLY. TOL: +/- .04 [+/- 1.0] WAS +/- .12 [+/- 3.1] FOR ALL OF COLUMN "F".	5797		R	
5	7/15/09	RVU		VOID				
4	10/20/08	RVU	LDG	CHANGE FORMAT 'B' TO 'A'. ADDED NEW COLUMNS OF "G" DIA., "H" R., VIEW 2 AND REVISED NOTES 2.	5571		R	
3	7-27-06	RVU	DWY	ADD TABLE "E" AND "F".	4583		R	
2	3-29-05	RVU	DWY	ADDED SIDE VIEW, VIEW 1, AND DIMENSIONS "A", "B", "C" AND "D".	3840		R	
1	3-25-03	RVU	DWY	DIMENSION 1.50 ± .125, 5.00 ± .125, & TOLERANCE ADDED. MISC. REVISIONS.	3207		R	
R	9-23-99	RVU	DWY	DRAWING RELEASE	1438		R	

PANDUIT CORP. TINLEY PARK, ILLINOIS

SAFETY LOCKOUT - PSL - **

UNLESS OTHERWISE SPECIFIED, DIMENSIONAL TOLERANCES ARE:
 (.X) ± (.XXX) ±
 (.XX) ± ANGLES ±

UNLESS OTHERWISE SPECIFIED, ALL DIMENSIONS ARE GIVEN IN INCHES, THIRD ANGLE PROJECTION.

DRAWN BY RVU

MAT'L:

C1018 STEEL ZINC PLATED WITH RED PVC COATING

SCALE NTS

DATE 9-23-99

DRAWING NO. C10099

CHK'D

6

DWG A SIZE